

KENNE BELL

Hi Tech Performance Products

Dear Customer,

All GM Kenne Bell supercharger kits require the purchaser to send us their factory Powertrain Control Module for reprogramming.

All the necessary forms are attached including photo of PCM and location. Make sure you **fill our form out completely** (no home made forms will be accepted) and send us the PCM so we can make our modifications and return it promptly to you.

Most reprogrammed PCMs are returned within 24 hours of day received if delivered in early Am. All PCMs will be shipped back standard ground service. Additional charges apply if customer wants overnight or 2 day air service. If you wish return shipment other than ground, MAKE SURE YOU NOTE THIS ON THE FORM IN THE CUSTOMER COMMENTS SECTION. YOU WILL BE CHARGED FOR THE ADDITIONAL FREIGHT AND HANDLING.

PLEASE NOTE: SOME PCMs REQUIRE MORE TIME TO REPROGRAM THE REQUIRED CHANGES. IN THIS CASE, RETURNED SHIPMENTS MAY BE SOMEWHAT DELAYED. DELAYS USUALLY ARE NO MORE THAN 2-3 DAYS UPON RECEIPT.

ALL PCMs WILL BE SHIPPED WITH A NEW SET OF INJECTORS THAT MUST BE INSTALLED ALONG WITH THE NEWLY PROGRAMMED PCM. THERE WILL BE A CHARGE OF \$599 AGAINST THE COST OF THE SUPERCHARGER KIT WHEN THE PCM AND INJECTORS SHIP. THE BALANCE OF THE KIT WILL BE CHARGED UPON SHIPMENT OF THE SUPERCHARGER KIT. THE VEHICLE MAY BE DRIVEN IN A NORMAL MANNER ONCE THE NEW KB INJECTORS AND REPROGRAMMED PCM ARE INSTALLED.

THANK YOU!

Kenne Bell Tech Dept.

SPEEDY CALIBRATION INFO SHEET FOR ALL CHEVY KITS.

Please completely fill out this form and include with your Chevy PCM. Kenne Bell is unable to perform the calibration without all information listed below. Be sure all spaces are filled in. We will NOT calibrate the PCM until the correct information is received. This information is for Kenne Bell record use only and is used strictly to speed the calibration process. Include this form with the PCM when sending to Kenne Bell. Any PCM received before 12:00 noon Monday thru Friday will be return shipped in 24 hours on the next business day.

Registered vehicle owners full name: _____

Owners phone:(____)_____ Owners fax:(____)_____ EMAIL: _____

Party who purchased supercharger from Kenne Bell: _____

Year of vehicle:_____ Engine size(liters):_____ 2wd or 4wd:_____

Vehicle model:_____

Speed limit desired:_____

Note: \$100 charge and waiver must be included, there is a max mph of 20% over stock.

Speedometer correction (if no modification has been made, write stock)

Gear ratio:_____ Tire size (height in inches):_____

Vehicle Emissions information:

Fill in data from vehicle emissions control information here only.

BOX 1 _____

BOX 2 _____

BOX 3 _____

THANK YOU,

PLEASE SEND THIS FORM ALONG WITH PCM TO:

KENNE BELL TECH DEPT.

10743 BELL CT.

RANCHO CUCAMONGA, CA 91730

PHONE: 909-941-6646

FAX: 909-944-4883

WARNING

DO NOT send us an altered GM PCM. No Hypertech, Diablo, or Superchip, etc. programs that allow you to raise the rev limiter or speed limiter or any other type of "tuning". These are dangerous modifications for supercharging. We know supercharging much better than they do!

If you want to purchase the supercharger kit, that's great. We want you to have it, but we cannot honor any warranties where any of these "custom settings" have been performed. We can tell when we look at your code if a Hypertech, Diablo, Superchip or any other PCM modifications have been made.

We will return freight collect any PCM's untouched that have been modified, without re-flashing them to our specs. You must then at your cost, reset ALL factory parameters you may have changed and resend your PCM back to us for modifications for the supercharger kit.

WARNING

KENNE BELL

IMPORTANT: The information below must be filled out COMPLETELY in order for us to ship your supercharger kit.

GM - SUPERCHARGER KIT SPEC SHEET

GM PCM SPEC SHEET

SHIP TO:		BILLING ADDRESS (CREDIT CARD ORDERS ONLY)	
NAME _____	ADDRESS _____	NAME _____	ADDRESS _____
CITY _____	STATE _____ ZIP CODE _____	CITY _____	STATE _____ ZIP CODE _____
PHONE (____) _____ - _____	FAX (____) _____ - _____	PHONE (____) _____ - _____	FAX (____) _____ - _____



CARD # _____ EXP. _____ *Cardholder Signature* _____

VEHICLE INFORMATION (FILL OUT COMPLETELY)

NOTE! IF THIS SHEET IS NOT FILLED OUT COMPLETELY, YOUR ORDER WILL NOT BE PROCESSED!

1. TYPE OF VEHICLE	COMPLETE MODEL DESC _____
2. YEAR OF VEHICLE	_____
3. TRANSMISSION	MANUAL _____ AUTOMATIC _____
4. ENGINE SIZE	_____ LITER
5. MASS AIR METER	STOCK _____ OTHER _____ DON'T KNOW _____
6. THROTTLE BODY	STOCK _____ OTHER _____ (SIZE) _____ MM MANUFACTURER _____
7. RAM AIR KIT	YES _____ NO _____ MANUFACTURER _____
8. HEADERS	STOCK _____ SHORTIE _____ LONG TUBE _____ MANUFACTURER _____
9. EXHAUST	STOCK _____ OTHER _____
10. CATS	YES _____ NO _____
11. MANIFOLD	STOCK _____ OTHER _____ TYPE _____ MANUFACTURER _____
12. HEADS	STOCK _____ OTHER _____ TYPE _____ MANUFACTURER _____
	PORTED? YES _____ NO _____
13. CAM (if known)	STOCK _____ CAM SPECS @ .050" (LIFT) INT _____ EXH _____ (DURATION) INT _____ EXH _____
14. AXLE RATIO	STOCK _____ OTHER _____ (TYPE) _____
15. IGNITION	STOCK _____ OTHER _____
16. SPEED LIMIT DESIRED	_____ STOCK _____ <i>(WAIVER MUST BE SIGNED IF OTHER THAN STOCK AND THERE IS A \$100 CHARGE EACH FOR CHANGING LIMITER, GEARS OR TIRES SIZES. NOTE: WE WILL NOT RAISE ANY REV LIMITERS ON KENNE BELL SUPERCHARGED VEHICLES!)</i>
17. FUEL USED	91 _____ 92 _____ 93 _____ 100 _____ RACING (MFG/OCTANE) _____ OTHER _____
18. DETONATION	YES _____ NO _____ RPM IT OCCURS _____
19. CUSTOMER COMMENTS	_____ _____ _____

IMPORTANT !
THIS SHEET MUST BE INCLUDED WITH SHIPMENT OF YOUR PCM TO US. IF THIS SHEET IS NOT COMPLETED OR INCLUDED, YOUR PCM WILL BE RETURNED TO YOU FREIGHT COLLECT WITHOUT BEING REPROGRAMMED.

I wish to have my PCM sent back Next Day Air _____ Two Day Air _____ - I understand I will be charged for freight. Please send back standard ground (no charge) _____.

PLEASE SEE PAGE 4 FOR PCM LOCATION AND INSTRUCTIONS ON REMOVAL

KENNE BELL GM 4.8, 5.3 AND 6.0 LITER V8 VORTEC PCM OVERVIEW

STEP 1. PCM location. PCM is located inside engine compartment on driver side, next to battery tray.

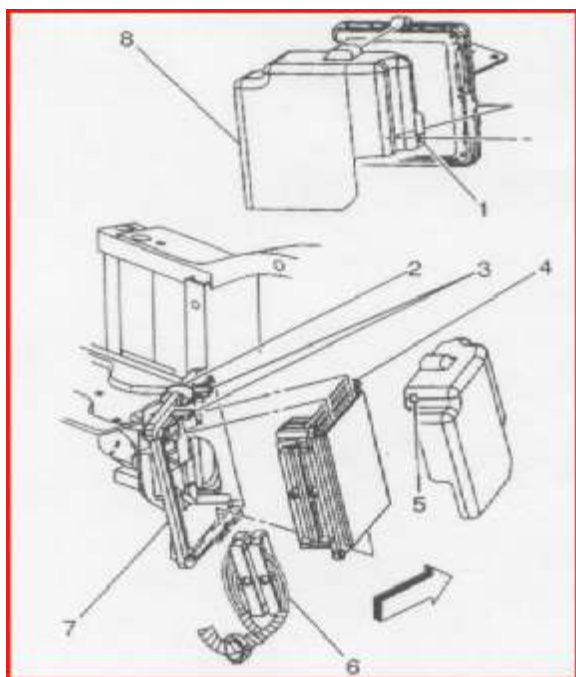

STEP 2. PCM removal.

1. Disconnect negative lead on battery.
2. Release the PCM cover mounting holes (1,5) away from the mounting tabs on the PCM mounting bracket.
3. Release the PCM cover (8) from mounting bracket.
4. Remove PCM cover.
5. Release the spring latch (2) from the PCM.
6. Release the PCM mounting tabs (3) from the PCM.
7. Remove the PCM (4) from the engine compartment.

*URGENT: PLEASE DELIVER TO THE
TECH DEPARTMENT IMMEDIATELY*

*GM PCM
ENCLOSED!*

When shipping your PCM to us for your Supercharger Kit, please cut this sheet on the dotted line and attach the TOP part ONLY to the OUTSIDE of the box you are shipping to us. THIS IS VERY IMPORTANT. If this form is not attached to your shipment, there may be a delay in returning your PCM. This is due to the large number of packages we receive every day that are delivered with no department notification on the outside of the package. If this form is not attached, the shipping department will not know to deliver your package right away to the tech department for the upgrade. If you wish to take advantage of our same day return shipment, you must also make sure your package is scheduled for early morning delivery WITH THIS FORM ATTACHED to allow us enough time to perform the upgrade and attempt to re-ship back to you the same day as received (see Page 1 of 4 for more information on return shipments). Kenne Bell makes every effort to attempt to ship computers back the same day as received, however, FAILURE TO SCHEDULE YOUR DELIVERY FOR EARLY MORNING DELIVERY TO KENNE BELL AND / OR LACK OF ATTACHING THIS SHEET TO THE OUTSIDE OF THE BOX, OR MISSING / INCORRECT INFORMATION INCLUDED BY YOU MAY DELAY RETURN OF YOUR COMPUTER. MAKE SURE YOUR METHOD OF PAYMENT IS FILLED OUT PROPERLY ON PAGE 3 OF 5. SHIPMENTS RECEIVED ON MONDAYS WILL NOT BE SHIPPED BACK UNTIL THE FOLLOWING DAY. DO NOT FORGET TO ALSO INCLUDE THE GM PCM SPEC SHEET (PAGE 3 OF 5) ON THE INSIDE OF THE BOX!

REMEMBER TO DO THE FOLLOWING:

- 1.) Reprogram your PCM back to factory stock if Hyper tech, Superchips, Diablo or other method was used to alter the PCM in ANY way.
- 2.) Make sure your package will be delivered early AM
- 3.) Attach TOP HALF ONLY of this sheet to OUTSIDE of your box.
- 4.) Include the Data Form INSIDE the box, including payment method.
- 5.) Include your PCM in the box.